

EC type-examination certificate UK/0126/0023 - Revision 5

Issued by:

NMO

Notified Body Number 0126

In accordance with the requirements of the Measuring Instruments Regulations 2016 (S.I. 2016 No. 1153) which implement, in the United Kingdom, Council Directive 2014/32/EU, this EU-type examination certificate has been issued to:

NDC Technologies Inc.

Bates Road

Maldon

Essex

CM9 5FA

In respect of a length measuring instrument designated the LS 9000-303 and having the following characteristics:

Operating Speed (S)	$0 < S \leq 2000$ m/min
Minimum length (Lm):	≥ 400 mm
Scale interval:	= 1 mm
Accuracy class:	I, II or III

The necessary data (principal characteristics, alterations, securing, functioning etc) for identification purposes and conditions (when applicable) are set out in the descriptive annex to this certificate.

This revision replaces previous versions of the certificate.

Issue date: 02 August 2018

Valid until: 30 January 2022



Grégory Glas

Lead Technical Manager

For and on behalf of the Head of Technical Services



0135

Descriptive Annex

1 INTRODUCTION

This pattern of length measuring instrument, designated the LS 9000-303 system, is a mains powered (110-230 VAC) industrial, laser-based measurement instrument for the determination of the length of rope-type materials (e.g. cables, bands etc.) during feed motion of the product to be measured.

2 FUNCTIONAL DESCRIPTION

2.1 Mechanical

The LS 9000 system, incorporates a LaserSpeed 9000 (LS 9000) laser head-works coupled to a DataPro 1000 (DP1000) data processor and indicator unit. The DP 1000 displays the velocity and length of the material moving under the beam of the laser, and has output alarms which are used to monitor the length and signal quality. The DP1000 may be connected to a PCL (printer control language) supported printing device, which will print Date, Time and Measure length.

Due to the nature of the laser-based measurement, there is no physical contact with the material.

The LS9000 is classified as a class III b laser device.

2.2 LS 9000

The LS9000 gauge has the ability to measure in both positive and negative directions, as well as zero-speed. The LS9000 is designed to work in applications where the material to be measured stops and reverses direction, or moves very slowly. The LS9000 can also measure material moving at speeds up to 2000 m/min.

The LS9000 is provided with a 24 Vdc supply by the DP 1000 unit via the 25 pin cable, which has a maximum length of 50 metres.

2.3 DP 1000

The DP1000 is a data processor and indicator designed for length and line speed applications. It displays the velocity and length of the moving material.

The DP1000 shows the measured length, product line speed, and Quality Factor at a given point in time. It has tolerances for the quality factor and length and can trigger relay alarms. It also can print the current length out the serial port or to a printer on command and/or at a user configured frequency. The quality factor value is relative to the "reflected" signal received by the LS900, and sent to the DP 1000.

The DP1000 can store 90 days of length data, with date and time, which can be downloaded via an Ethernet communications interface.

The DP 1000 is mounted into an industry standard 19" rack mount cabinet. The front panel of the cabinet is fitted with a mains supply ON/OFF pushbutton and a laser shutter interlock key to control the operation of the device. The legend on the cabinet indicates which position corresponds to "Laser On" and "Laser Off."

The key is removable only in the "Laser Off" position.

2.3.1 Access levels

- level 0 at connection/power up (with no log in), access to view the Data Pages and the Status Pages only.
- level 1 –User (e.g. line operator) - access to view the Data Pages, Status Pages plus the Main Setup Menu/Pages. Only parameters that do not affect the values displayed or recorded by the instrument can be changed. The type of parameters that can be changed are tolerances for the quality factor, length relays, machine number, product number.
- level 2 –Supervisor – access to view DataPro 1000 screens i.e. Data Pages, Status Pages, Main Setup Menu/Pages and Global Setup Menu/Pages. In addition to level 1 the items that can be changed are the formatting of the reports.

2.4 Input / Output connections

2.4.1 The rear of the DP 1000 has connections for:

- mains power,
- DB25 communication and power to the LS 9000 (25 pin)
- DB9 RS-232 output, data request and transmit (9 pin)
- USB to printer
- RJ-45 Ethernet, data request and transmit
- DB25 (User Connection) RS-232, Relay output, Digital Input (25 pin)

2.4.2 The top of the LS 9000 has connections for:

- Communication (to DP1000) and power to the LS 9000 (25 pin)

The following are not used, and are closed and secured:

- Serial output (9 pin) - RS-422 Transmit/Receive (from LS9000 to host - host to LS9000)
- M12 Connector – Ethernet Transmit/Receive (from LS9000 to host/switch - host/switch to LS9000)

3 PRINCIPLE OF OPERATION

3.1 LaserSpeed utilizes dual-beam interferometer technology to provide velocity readings. The measured velocity is integrated over time to measure the length of moving objects. The opto-electronic portion of the LS9000 generates a laser beam that is split and then crossed in space. The two crossing beams interact, producing a fringe pattern that is orthogonal to the plane of the beams.

Light is scattered when material passes through the measurement region. This scattered light is collected by the gauge and converted to electrical signals. The frequency of the electrical signal contains information with regards to the velocity of the material. The signal processor converts the electrical signals to frequency information that is directly proportional to the velocity of the material moving through the laser beams. The signal processor converts the frequency information into velocity information and updates user outputs.

In order to determine if there is an object in the measurement area, the gauge measures the amount of reflected laser light and the result.

3.2 The LS 9000 has the following characteristics:

Operating Speed (S)	$0 < S \leq 2000$ m per min
Minimum length (Lm):	≥ 400 mm
Scale interval:	= 1 mm
Accuracy class:	I, II or III
Standoff Distance:	300 mm +/- 17.5 mm
Measurement Depth of Field:	35 mm
Gauge Power:	120@ 4 Amps
Lower & Upper temperature limits:	+5°C to +40°C
Climatic Environment:	Closed, Non-condensing
Mechanical Environment:	M3
Electromagnetic Environment:	E2

3.3 The LS 9000 has the following system specification:

Maximum Laser Power	0.050 watt
Laser Wavelength	0.785 micrometers
Laser Spot Size (Elliptical)	3 x 1.5 mm
Beam Divergence	0.5 milliradians
Pulse Rate	Continuous wave
Maximum radiance (power divided by spot-size area)	0.050 Watt/0.141372 cm ² [0.3536 W/cm ²]

3.4 SOFTWARE

3.4.1 The software in the DP 1000 is Version 1.00. The software version, and date of software release, can be displayed on the instrument using the following procedure.

Select:

- “Access to/from Menus and Data pages” via the keypad (see Figure 2)
- Option 4 “About”
- “Next page” via the keypad (see Figure 2)

Software identification is via the version number, X.yy, where:

- X indicates a change to the legally relevant software and requires a change to the type approval certification, and
- yy indicates a change to the non-legally relevant software.

3.4.2 Software changes

Any legally relevant software change requires destroying the tamper evident seals on the cover of the DP 1000. This operation is carried out by the manufacturer’s authorised personnel at an authorized service centre. The action is recorded on a certification sheet which is stored at the facility, as well as the update of the new version number on the display, when the seals are replaced. Software changes are not to be made in the field as this requires re-certification of the gauge and reapplication of the tamper evident seals. Figure 4 shows the positions of the tamper evident seals and a data sheet for the seals.

4 PERIPHERAL DEVICES AND INTERFACES

4.1 Interfaces

The DP 1000 has the following interfaces:

- 4 internal dry contact relay outputs for alarm outputs indicators
- 5 opto-isolated digital inputs that can be used to:
 - End of Reel Report (printed report).
 - Transmit Length over RS-232 and Ethernet.
 - Transmit Length with headers over RS-232 and Ethernet.
 - Transmit Stored Data over Ethernet.
 - Externally control the Length Reset feature of the LS9000.

4.2 Peripheral devices

4.2.1 The instrument may be connected to any peripheral device that has been issued with a test certificate by a Notified Body responsible for Annex B (MI-009) under Directive 2004/22/EC in any Member State and bears the CE marking of conformity to the relevant directives; or

A peripheral device without a test certificate may be connected under the following conditions:

- it bears the CE marking for conformity to the EMC Directive 89/336/EEC;
- it is not capable of transmitting any data or instruction into the instrument, other than to release a printout, checking for correct data transmission or validation;
- it prints results and other data as received from the instrument without any modification or further processing; and
- it complies with the applicable requirements of Paragraph 8.1 of Annex I

4.2.2 A computer with an RS-232 serial port, using the “LaserTrak Software” or directly using the serial commands listed in the Communication Protocol section, can be used to check the configuration and setup of the gauge. The settings in the LaserSpeed are fixed at the factory and are read-only. They can not be changed using any of the above methods.

5 APPROVAL CONDITIONS

The certificate is issued subject to the following conditions:

5.1 Legends and inscriptions

5.1.1 The instrument bears the following legends:

‘CE’ marking
Supplementary metrology marking
Notified body identification number
Accuracy class
Manufacturers mark or name
Type examination certificate number
Operating Speed (S)
Minimum length (Lm)
Scale interval

6 LOCATION OF SEALS AND VERIFICATION MARKS

6.1 Set-up data is stored within the non-volatile memory of the DP1000.

6.2 The 'CE' marking, supplementary metrology marking and certificate number are located on the DP1000. The markings shall be impossible to remove without damaging them.

The markings and inscriptions shall fulfil the requirements of Paragraph 9 of Annex I of the Directive 2004/22/EC.

6.3 Components that may not be dismantled or adjusted by the user will be secured by either a wire and seal or tamper evident label and securing mark. The securing mark may be either:

- a mark of the manufacturer and/or manufacturer's representative, or
- an official mark of a verification officer.

6.4 The LaserSpeed 9000 and the DataPro 1000 are both fitted with a tag, which bear the same serial number to identify the units as a "system". The tag shall be impossible to remove without damaging it.

7 ALTERNATIVES

7.1 Having a length measuring instrument designated the LS 9000-306, with following characteristics:

Standoff Distance:	600 mm +/- 25 mm
Measurement Depth of Field:	50 mm
Gauge Power:	240 @ 4 Amps

7.2 Having a second DB25 connection fitted to the rear of the DP 1000. This allows for connection of the DP 1000 to a peripheral device, as detailed in section 4.2.1, a typical application of which is for use in providing information regarding the monitoring of system functions such as product speed. The connector is labelled "USER PULSE OUTPUT".

7.3 Having the Safety Key Switch on the front panel wired to the rear panel to allow the customer to break the signal to shut off the laser for safety. When this circuit is broken, the system will require 8 seconds to reactivate the laser after the circuit is reset. This is wired to the "USER CONNECTIONS".

7.4 Having the LaserSpeed 9000 (LS 9000) laser head-works and DataPro 1000 (DP1000) mounted into a safety cabinet (see Figure 5).

7.4.1 A 2 segment light is mounted onto the top of the cabinet:

- The RED segment will illuminate when the Laser is in operation
- The YELLOW segment will illuminate when the Quality Factor (QF) falls below the acceptable value (i.e.15)

7.4.2 Each door of the cabinet is fitted with a contact switch. If the door is opened the switch will operate a relay that stops the product feed and close the mechanical shutter of the laser stopping any measurement.

7.4.3 When the doors are closed the mechanical shutter of the laser will open, the product feed will start and the measurement will continue.

7.4.4 The self centring product guides, fitted inside the cabinet, are set manually according to product and size.

7.4.5 Having alternative positions for the verification marks, as shown in Figure 4a.

7.5 Having an alternative laser head-works model designated the Laserspeed Pro 9500 (Model LS Pro 9500) which is connected to the DP 1000. The LS Pro 9500 has the same technical characteristics as the LS 9000 but has a different housing and some minor design changes to the electronics.

8 ILLUSTRATIONS

Figure 1	LS 9000
Figure 2	DP 1000 front panel
Figure 3	Schematic of connection
Figure 4	Position of verification marks and tamper evident seals
Figure 4a	Alternative position of verification marks
Figure 5	Safety cabinet
Figure 6	Model LS Pro 9500

9 CERTIFICATE HISTORY

ISSUE NO.	DATE	DESCRIPTION
UK/0126/0023	25 January 2008	Type examination certificate first issued.
UK/0126/0023 Rev 1	11 June 2009	Revision 1 issued. Creation of sections 7.2 & 7.3.
UK/0126/0023 Rev 2	02 November 2010	Revision 2 issued. Creation of section 7.4
UK/0126/0023 Rev 3	20 March 2014	Revision 3 issued. Change of certificate company title to "Beta LaserMike Inc." Addition of certificate accuracy class to include "II" and "III". Section 3.2 - Addition of "+/- 17.5 mm" to standoff distance, to help explain depth of field distance. Section 3.4.1 - Re-wording of "s/ware" to "software" Section 3.4.2 - Removal of a reference to an EPROM. Section 7.1 - Addition of "+/- 25 mm" to standoff distance, to help explain depth of field distance. Addition of Section 7.4.5 & Figure 4a - Alternative location of "Verification marks" information.

UK/0126/0023 Rev 4	25 February 2015	Revision 4 issued. Change of certificate company title to "NDC Technologies Inc."
UK/0126/0023 Rev 5	02 August 2018	Revision 5 issued. Addition of Section 7.5 and Figure 6.

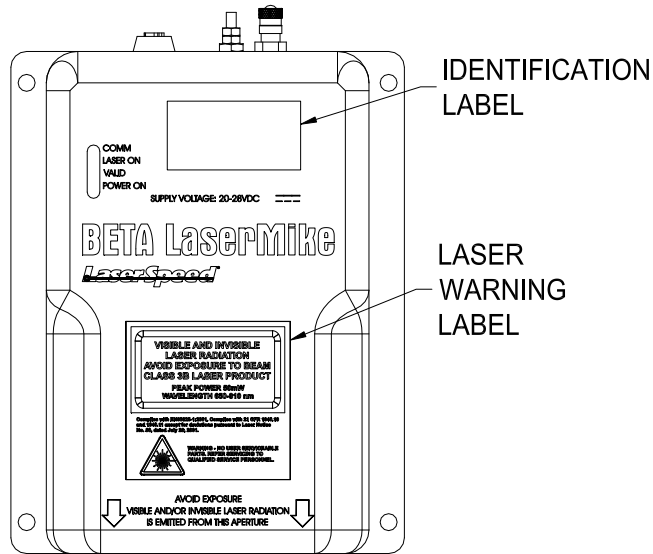

Figure 1 LS 9000

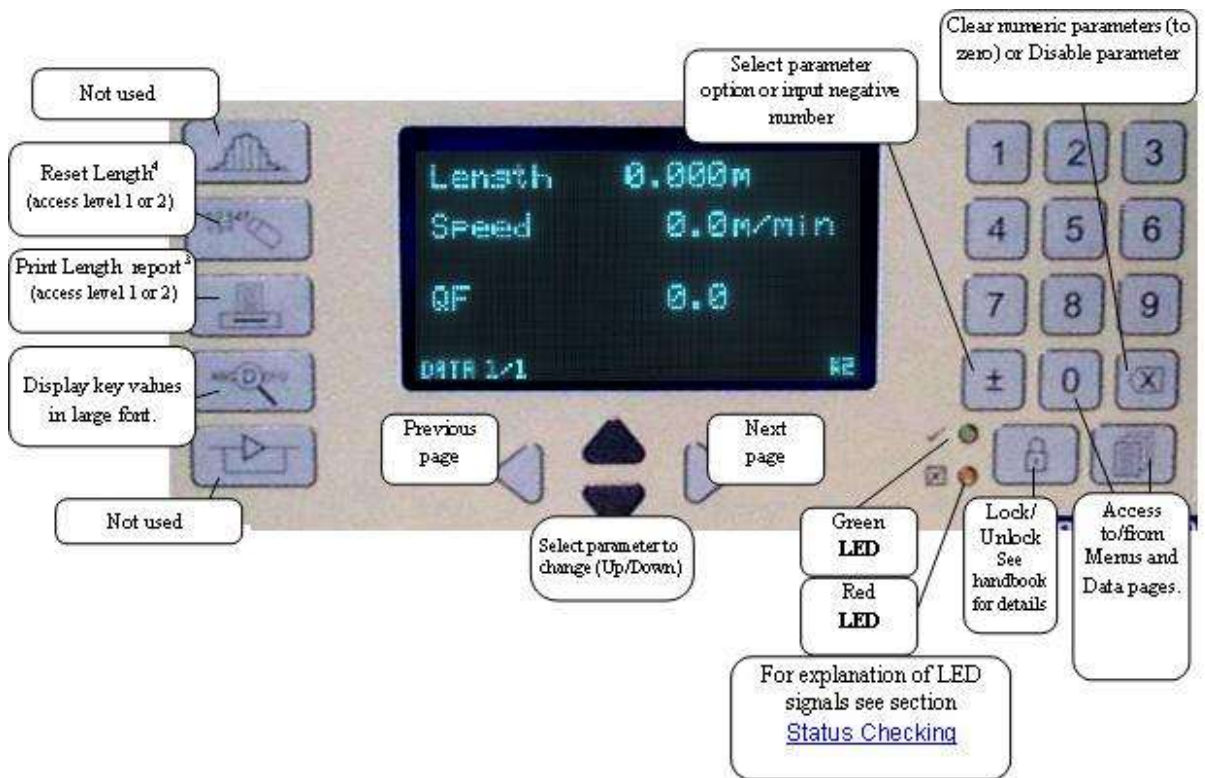

Figure 2 DP 1000 front panel

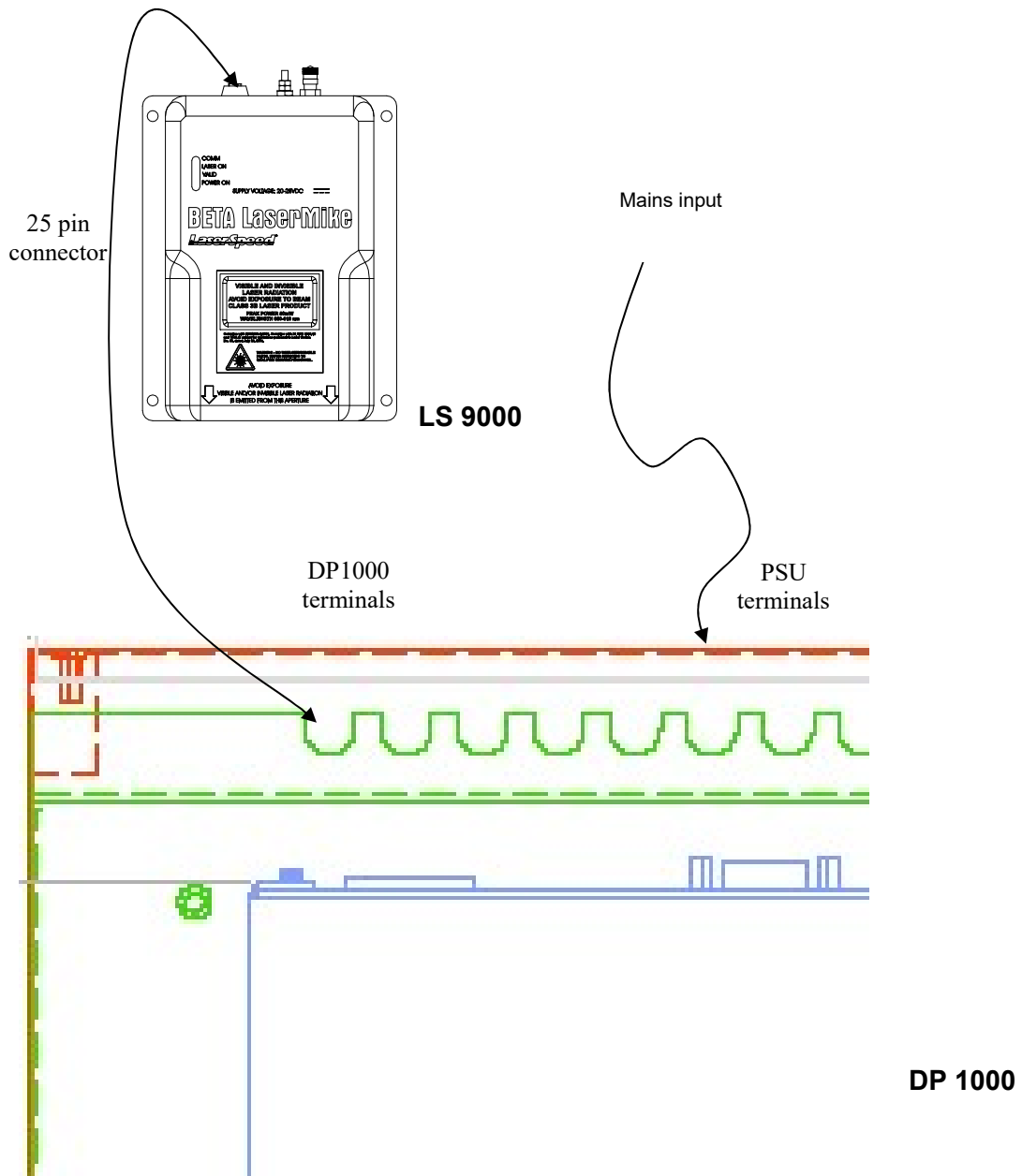

Figure 3 Schematic of connection

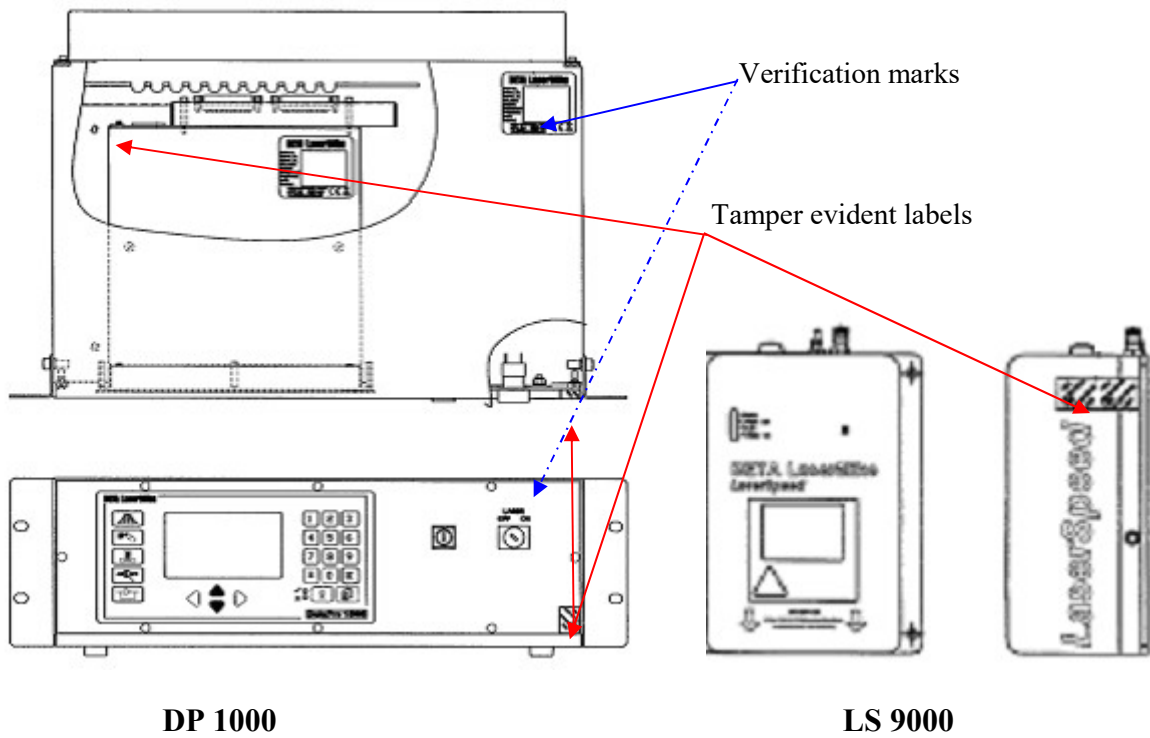

Figure 4 Position of verification marks and tamper evident labels

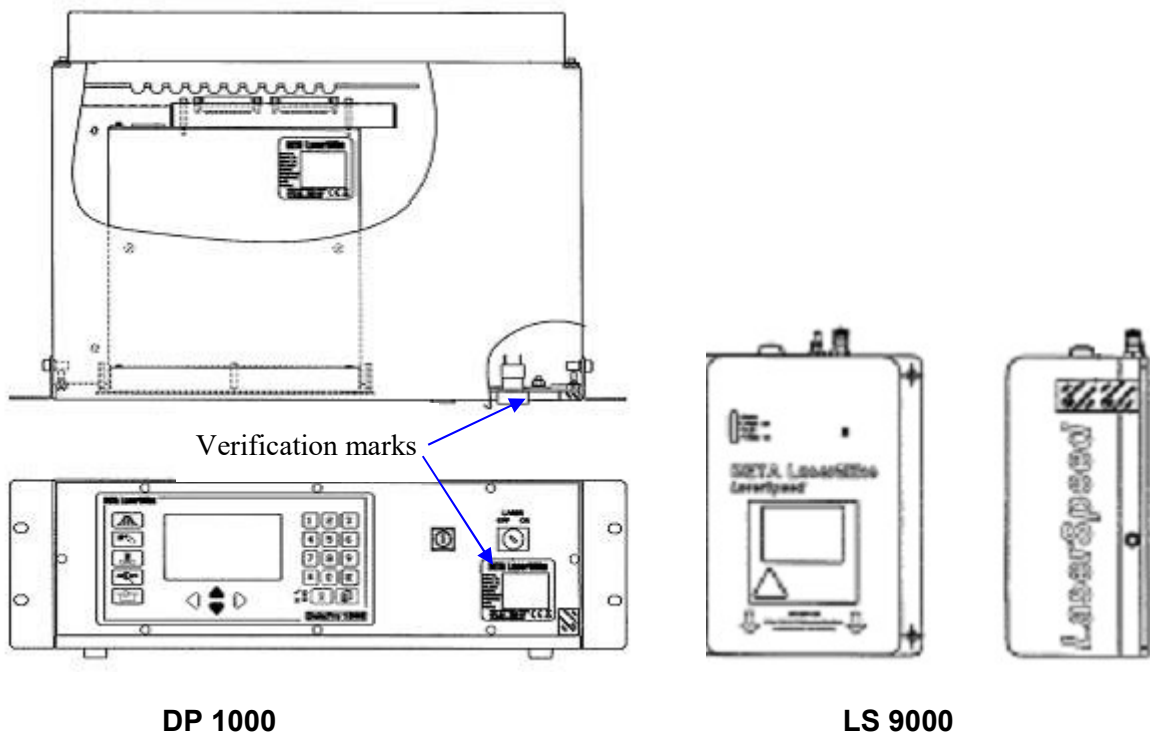

Figure 4a Alternative position of verification marks



Figure 5 Safety cabinet

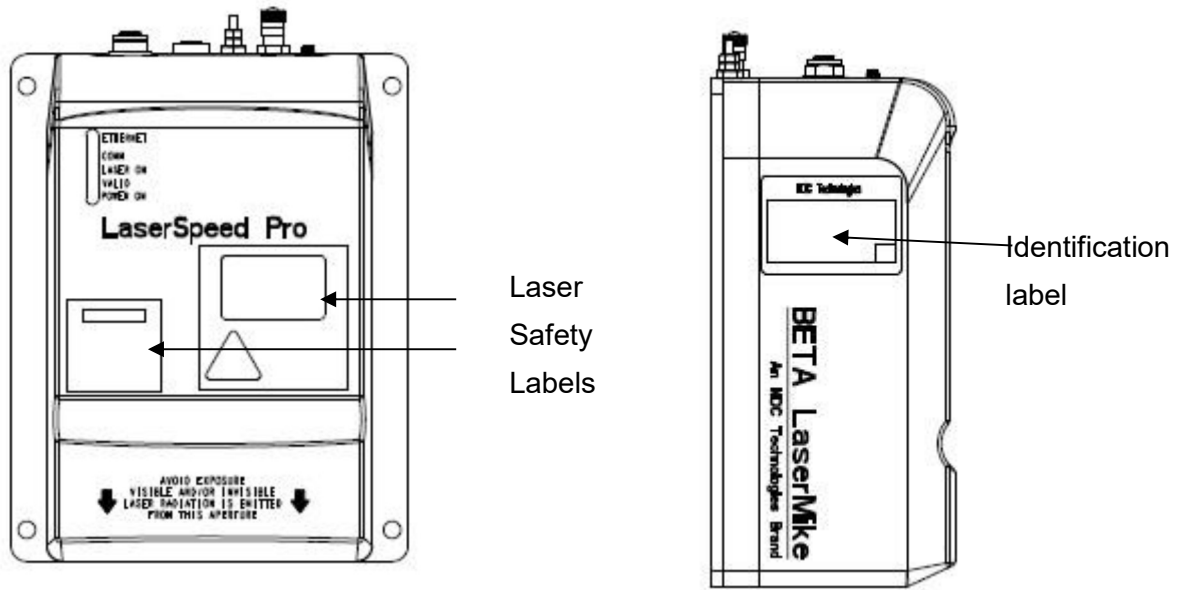

Figure 6 Model LS Pro 9500